

EBR Interlocked Circuit Breaker Receptacle

Explosionproof, Dust-Ignitionproof, Weather Resistant

30, 60, 100 and 150 Amp, 600 Vac

CEC:

Class I, Groups B, C, D

Class II, Group G and Coal Dust

Class III

CSA Type 3*, 3R*, 4*, 4X*, 7CD, 9G, 12

Applications

- The EBR is designed to connect portable electrical equipment for use in hazardous areas such as:
 - Compressors
 - Conveyors
 - Motor generators
 - Air conditioners
 - Heaters
- Its construction and features provide short circuit protection and is ideally suited for use in:
 - Damp, wet locations
 - Corrosive areas
 - Indoor or outdoor
 - Hazardous or non-hazardous locations
- Class I: classified locations such as:
 - Refineries
 - Petrochemical plants
 - Petroleum refineries
 - Paint and chemical plants
 - Any location where ignitable vapors or gases are present
- Class II: classified locations such as:
 - Process industries where there are dust hazards from handling such products as flour, grain and starch
 - Any location where ignitable amounts of dust are present or amounts which would adversely affect performance



- 1 N/O and 1 N/C Auxiliary Contacts – Suffix **-XLK**.
- 2 N/O and 2 N/C Auxiliary Contacts – Suffix **-2XLK**.
- CSA 4X ▽ Versions available. Add suffix **-4X**.

Features

- Plug is mechanically locked in receptacle when circuit breaker is "ON". Design provides interlocked connect and disconnect operation as well as short circuit and thermal time delay overload protection.
- Plug and receptacle contacts cannot be made or broken under load. Breaker operating handle can be padlocked in either "ON" or "OFF" position and is trip free.
- Body is easily installed with 4 mounting brackets provided, each having keyhole slots. Body has three 1 1/2" taper tapped conduit openings – (1) top and (2) bottom. Also provided are 3/4" threaded openings (3/4" -1/2" reducer furnished) top and bottom for installation of optional drain and breathers.
- Appleton's EBR explosion-proof receptacle with interlocked circuit breakers utilize either ACP or CPH series plugs.
- The cover is secured with captive quick-bolts for easy installation or removal.
- Receptacle ratings available are 30, 60, and 150 Amp.
- Circuit Breakers are thermal-magnetic type – 150 Amp frame size, 20 to 100 Amp trip.

Standard Materials and Finishes

- Receptacle and mounting box: copperfree (4/10 of 1% max.) aluminum with gray epoxy coated inside and out
- Quick-bolts and hinge pins: stainless steel

CEC Certifications and Compliances

- CSA Standard: C22.2 No. 25, C22.2 No. 30, C22.2 No. 159, C22.2 No.182.1
- CSA Certified: 038644

Options

- Special Polarization: Prevents plug insertion in a receptacle or connector wired for a different voltage. In installations where there are different line voltages, the special polarization option is desirable. This allows only plugs and receptacles wired for the same line voltage to be mated together. The receptacle or connector interior is positioned 22-1/2°, relative to the polarization rivet, to the right (as specified) of standard, and plug is polarized to correspond. This option can be added to receptacles using the Powertite™ Plug. Suffix **-PR** to receptacle or plug.

• Flip cover suitable for NEMA 3, 3R only.

▼ NEMA 4 rating maintained with Appleton NEMA 4 plug installed. Install screw cover for 4, 4X. Both covers are included with product. The EBR will also accept Crouse-Hinds APJ series plugs. Crouse-Hinds and APJ are registered trademarks of Cooper Crouse-Hinds.

EBR Interlocked Circuit Breaker Receptacle

Explosionproof, Dust-Ignitionproof, Weather Resistant

30, 60, 100 and 150 Amp, 600 Vac

CEC:

Class I, Groups B, C, D

Class II, Group G and Coal Dust

Class III

CSA Type 3*, 3R*, 4*, 4X*, 7CD, 9G, 12



Solderless lugs are provided for line connections, and receptacle is prewired to the load side of breaker. Cover-mounted components leave entire enclosure space free for pulling of line conductors and wiring.

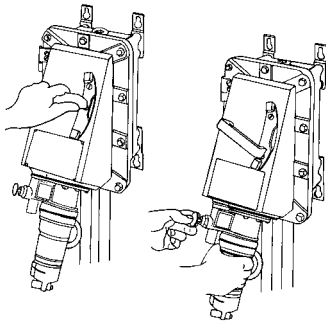

Plug is mechanically locked in receptacle when circuit breaker is ON. Design provides interlocked connect and disconnect operation as well as short circuit and thermal time delay overload protection.

Breaker operating handle can be padlocked in either ON or OFF position and is trip-free.

Enclosure has additional 3/4" threaded openings top and bottom for installation of optional drain and breather; reducers furnished.

- Flip cover suitable for NEMA 3, 3R only.
- ▼ NEMA 4 rating maintained with Appleton NEMA 4 plug installed. Install screw cover for 4, 4X. Both covers are included with product.
- ◀ Cutler-Hammer is a registered trademark of Eaton Corporation.

Horsepower Tables

These Cutler-Hammer * circuit breaker recommendations are for induction motors running with usual speed and torque characteristics. Ambient temperature, and frequency of starting could require different protective characteristics.

	HP	120 Vac	240 Vac	480 Vac	600 Vac
2W, 3P, 1-Phase, 30 Amp 2-Pole	1	40EHD	20EHD	15EHD	15FDB
	1-1/2	40EHD	30EHD	15EHD	15FDB
	2	50EHD	30EHD	20EHD	15FDB
	3	—	40EHD	30EHD	20FDB
	5	—	—	40EHD	30FDB
2W, 3P, 1-Phase, 60 Amp 2-Pole	7-1/2	—	—	40EHD	40FDB
	3	50EHD	—	—	—
	5	100EHD	50EHD	—	—
	7-1/2	—	70EHD	—	—
3W, 4P, 3-Phase, 30 Amp 3-Pole	10	—	—	50EHD	40FDB
	1	—	15EHD	15EHD	15FDB
	1-1/2	—	15EHD	15EHD	15FDB
	2	—	20EHD	15EHD	15FDB
	3	—	30EHD	15EHD	15FDB
	5	—	40EHD	20EHD	20FDB
	7-1/2	—	50EHD	30EHD	30FDB
	10	—	—	40EHD	30FDB
	15	—	—	40EHD	40FDB
	20	—	—	—	50FDB
3W, 4P, 3-Phase, 60 Amp 3-Pole	10	—	50EHD	—	—
	15	—	70EHD	—	—
	20	—	—	50EHD	—
	25	—	—	50EHD	50FDB
	30	—	—	70EHD	50FDB
	40	—	—	—	70FDB
	20	—	100EHD	—	—
	25	—	100EHD	—	—
3W, 4P, 3-Phase, 100A and 150 Amp 3-Pole	30	—	150FD	—	—
	40	—	—	100EHD	—
	50	—	—	100EHD	100FDB
	60	—	—	125FD	125FDB
	75	—	—	—	125FDB

Circuit Breaker Data — Cutler-Hammer *

Frame	Continuous		Interrupting Ratings (RMS SYM Amp)		
	Amp	Max Volts	240 Vac	480 Vac	600 Vac
EHD	20-100	480	18,000	14,000	—
FDB	20-125	600	18,000	14,000	14,000
FD	20-150	600	65,000	25,000	18,000
HFD	20-100	600	100,000	65,000	25,000

Horsepower Rating Table — Disconnect Switch

Max. Amp	Max. Horsepower Rating				
	120 Vac	240 Vac	480 Vac	600 Vac	250 Vdc
30	5	10	20	25	7-1/2
60	10	20	40	60	15
100	15	30	75	75	25
150	—	50	100	150	—

Appleton

PLUGS AND RECEPTACLES: NEC/CEC HAZARDOUS LOCATION

EBR Interlocked Circuit Breaker Receptacle

Explosionproof, Dust-Ignitionproof, Weather Resistant

30, 60, 100 and 150 Amp, 600 Vac

CEC:
 Class I, Groups B, C, D
 Class II, Group G and Coal Dust
 Class III
 CSA Type 3*, 3R*, 4*, 4X*, 7CD, 9G, 12

Receptacle Description	Circuit Breaker		With 480 Vac		With 600 Vac	
	Amp	Pole	EHD Breaker	FDB Breaker	FD Breaker	HFD Breaker
30 Amp 2W 3P	20	2	EBR3023EHD20W	EBR3023FDB20W	EBR3023FD20W	EBR3023HFD20W
	30		EBR3023EHD30W	EBR3023FDB30W	EBR3023FD30W	EBR3023HFD30W
	40		EBR3023EHD40W	EBR3023FDB40W	EBR3023FD40W	EBR3023HFD40W
	50		EBR3023EHD50W	EBR3023FDB50W	EBR3023FD50W	EBR3023HFD50W
30 Amp 3W 4P	20	3	EBR3034EHD20W	EBR3034FDB20W	EBR3034FD20W	EBR3034HFD20W
	30		EBR3034EHD30W	EBR3034FDB30W	EBR3034FD30W	EBR3034HFD30W
	40		EBR3034EHD40W	EBR3034FDB40W	EBR3034FD40W	EBR3034HFD40W
	50		EBR3034EHD50W	EBR3034FDB50W	EBR3034FD50W	EBR3034HFD50W
60 Amp 2W 3P One Threaded (1-1/2") Conduit Opening in Top	50	2	EBR6023EHD50W	EBR6023FDB50W	EBR6023FD50W	EBR6023HFD50W
	60		EBR6023EHD60W	EBR6023FDB60W	EBR6023FD60W	EBR6023HFD60W
	70		EBR6023EHD70W	EBR6023FDB70W	EBR6023FD70W	EBR6023HFD70W
	90		EBR6023EHD90W	EBR6023FDB90W	EBR6023FD90W	EBR6023HFD90W
	100		EBR6023EHD100W	EBR6023FDB100W	EBR6023FD100W	EBR6023HFD100W
60 Amp 3W 4P	50	3	EBR6034EHD50W	EBR6034FDB50W	EBR6034FD50W	EBR6034HFD50W
	60		EBR6034EHD60W	EBR6034FDB60W	EBR6034FD60W	EBR6034HFD60W
	70		EBR6034EHD70W	EBR6034FDB70W	EBR6034FD70W	EBR6034HFD70W
	90		EBR6034EHD90W	EBR6034FDB90W	EBR6034FD90W	EBR6034HFD90W
	100		EBR6034EHD100W	EBR6034FDB100W	EBR6034FD100W	EBR6034HFD100W
100 Amp 2W 3P	50	2	EBR1023EHD50W	EBR1023FDB50W	EBR1023FD50W	EBR1023HFD50W
	70		EBR1023EHD70W	EBR1023FDB70W	EBR1023FD70W	EBR1023HFD70W
	90		EBR1023EHD90W	EBR1023FDB90W	EBR1023FD90W	EBR1023HFD90W
	100		EBR1023EHD100W	EBR1023FDB100W	EBR1023FD100W	EBR1023HFD100W
100 Amp 3W 4P	50	3	EBR1034EHD50W	EBR1034FDB50W	EBR1034FD50W	EBR1034HFD50W
	70		EBR1034EHD70W	EBR1034FDB70W	EBR1034FD70W	EBR1034HFD70W
	90		EBR1034EHD90W	EBR1034FDB90W	EBR1034FD90W	EBR1034HFD90W
	100		EBR1034EHD100W	EBR1034FDB100W	EBR1034FD100W	EBR1034HFD100W
150 Amp 3W, 4P	100	3	N/A	N/A	EBR15034FD100W ①	N/A
	125		N/A	N/A	EBR15034FD125W ①	N/A
	150		N/A	N/A	EBR15034FD150W ①	N/A



Two Threaded
(1-1/2")
Conduit Openings
in Bottom

ACP Plugs for EBR Receptacles

Cable Dia. (Inches)	30 Amp		60 Amp		100 Amp		150 Amp
	2W, 3P	3W, 4P	2W, 3P	3W, 4P	2W, 3P	3W, 4P	3W, 4P
.500 to 1.250	ACP3023BC	ACP3034BC	—	—	—	—	—
.500 to 1.375	—	—	ACP6023BC	ACP6034BC	—	—	—
.875 to 1.375	—	—	—	—	ACP1023CD	ACP1034CD	—
1.09 to 2.187	—	—	—	—	—	—	ACP15034CD
	—	—	—	—	—	—	ACP15034DE

• Flip cover suitable for NEMA 3, 3R only.
 ▼ NEMA 4 rating maintained with Appleton NEMA 4 plug installed. Install screw cover for 4, 4X. Both covers are included with product.
 ① Molded Case Switch available. Add suffix -K.

EBR Interlocked Circuit Breaker Receptacle

Explosionproof, Dust-Ignitionproof, Weather Resistant

30, 60, 100 and 150 Amp, 600 Vac

CEC:

Class I, Groups B, C, D

Class II, Group G and Coal Dust

Class III

CSA Type 3*, 3R*, 4*, 4X*, 7CD, 9G, 12

Dimensions in Millimeters (Inches)

Shown with Flip Cover

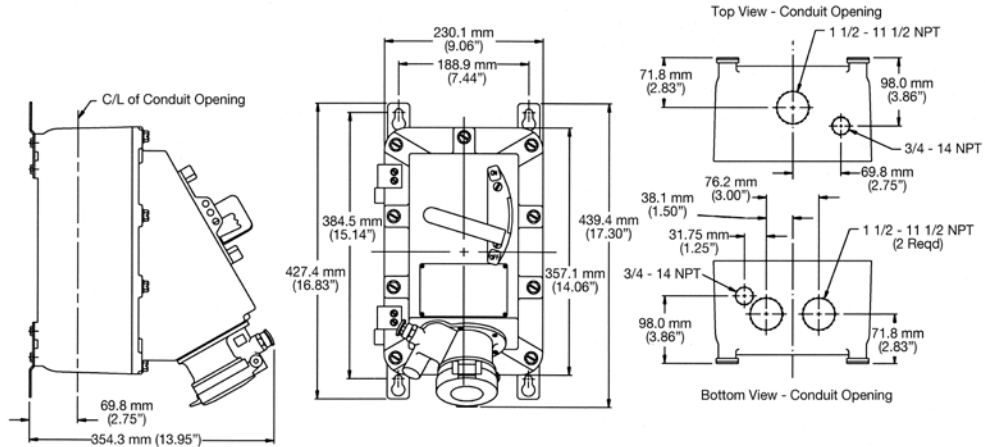

Shown with Screw Cover

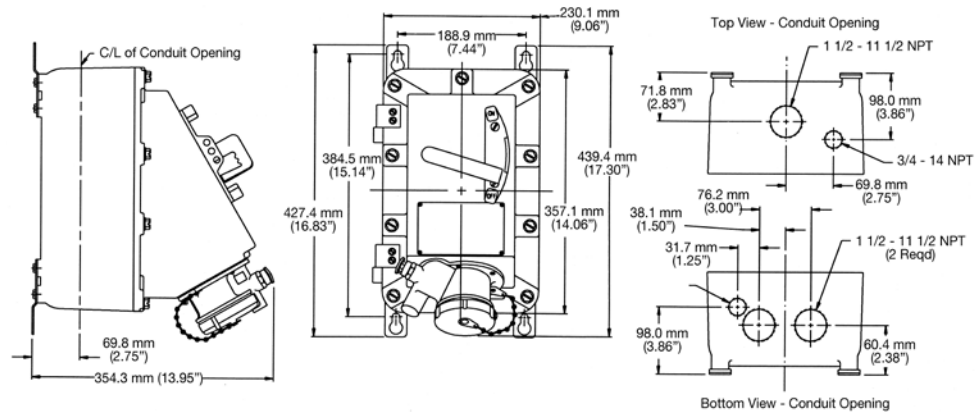

ACP Plugs

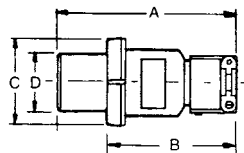

Max. Amp	No. Poles	Dimensions in Millimeters (Inches)			
		A	B	C	D
30	2,3,4	152.4 (6.00)	120.6 (4.75)	79.5 (3.13)	47.2 (1.86)
60	2,3	198.3 (7.81)	125.4 (4.94)	88.9 (3.50)	56.6 (2.23)
60	4	198.3 (7.81)	125.4 (4.94)	96.7 (3.81)	64.7 (2.55)
100	2,3	266.7 (10.50)	168.4 (6.63)	101.6 (4.00)	62.7 (2.47)
100	4	266.7 (10.50)	168.4 (6.63)	107.9 (4.25)	69.0 (2.72)

• Flip cover suitable for NEMA 3, 3R only.

▼ NEMA 4 rating maintained with Appleton NEMA 4 plug installed. Install screw cover for 4, 4X. Both covers are included with product.

Appleton

PLUGS AND RECEPTACLES: NEC/CEC HAZARDOUS LOCATION